

# Am29BL162C

## Data Sheet Supplement for PROM Programmer Manufacturers

This supplement is for use with the Am29BL162C data sheet, publication number 22142. This document describes the sector protection and sector unprotection functions intended for programming equipment. The Am29BL162C device also offers in-system sector protection and unprotection. Refer to the data sheet for more information.

### Sector Protection

The Am29BL162C features hardware sector protection. This feature will disable both program and erase operations in any number of available sectors. The sector protect feature is enabled using programming equipment *at the user's site*. Devices are shipped with all sectors unprotected. Alternatively, AMD may program and protect sectors in the factory prior to shipping the device (AMD's ExpressFlash™ Service).

To activate the sector protect mode, apply  $V_{CC} = 3.3\text{ V} \pm 10\%$ ; the programming equipment must then force  $V_{ID}$  on address pin A9 and control pin OE#, ( $V_{ID} = 12\text{ V} \pm 0.5\text{ V}$ ),  $V_{IL}$  on CE#, A6, and A0,  $V_{IH}$  on A1 and RESET#. The sector addresses on A19–A12 should be set to the sector to be protected. Programming of the protection circuitry begins on the falling edge of the WE# pulse and is terminated with the rising edge of the same. Sector addresses must be held constant during the WE# pulse. Refer to Figure 1 and Figure 2 for sector protection algorithm and waveforms. Remove  $V_{ID}$  prior to removing  $V_{CC}$ .

To verify programming of the protection circuitry, the programming equipment must force  $V_{ID}$  on address pin A9 with CE# and OE# at  $V_{IL}$  and WE# at  $V_{IH}$ . Scanning the sector addresses on A19–A12 while (A6, A1, A0) = ( $V_{IL}$ ,  $V_{IH}$ ,  $V_{IL}$ ) will produce 01h at device outputs (DQ0–DQ7) for a protected sector. In this mode, the lower order addresses, except for A0, A1, and A6 are don't care. Address locations with A1 =  $V_{IL}$  are reserved for Autoselect manufacturer and device codes.

### Sector Unprotection

Sectors previously protected may subsequently be unprotected to accommodate code changes, using the Sector Unprotect Mode. Prior to initiating a code change in any previously protected sector **all sectors** must be placed into the Sector Protect Mode using the Sector Protection Algorithm.

To activate sector unprotection, apply  $V_{CC} = 3.3\text{ V} \pm 10\%$ ; the programming equipment must then force  $V_{ID}$  on address pin A9 and control pin OE# ( $V_{ID} = 12\text{ V} \pm 0.5\text{ V}$ ),  $V_{IL}$  on CE# and A0,  $V_{IH}$  on RESET#, A1, and A6. The sector addresses on A19–A12 should be set to the sector to be unprotected. The unprotection mechanism begins on the falling edge of the WE# pulse and is terminated with the rising edge of the same. Refer to Figure 3 and Figure 4 for sector unprotection algorithm and waveforms. Remove  $V_{ID}$  prior to removing  $V_{CC}$ .

Verification of sector unprotection is similar to that for sector protection. The programming equipment must force  $V_{ID}$  on address pin A9 with CE# and OE# at  $V_{IL}$  and WE# at  $V_{IH}$ . Scanning the sector addresses on A19–A12 while (A6, A1, A0) = ( $V_{IH}$ ,  $V_{IH}$ ,  $V_{IL}$ ) will produce 00h at device outputs (DQ0–DQ7) for an unprotected sector. In this mode, the lower order addresses, except for A0, A1, and A6, are don't care. Address locations with A1 =  $V_{IL}$  are reserved for Autoselect manufacturer and device codes.

Note that the temporary sector unprotect procedure can be found in the Am29BL162C data sheet.

## DC CHARACTERISTICS

Parameter Symbol	Parameter Description	Test Conditions	Min	Max	Unit
$V_{ID}$	Voltage for Autoselect and Sector Protection	$V_{CC} = 3\text{ V}$	11.5	12.5	V
$V_{IH}$	Input High Voltage		$0.7 \times V_{CC}$	$V_{CC} + 0.3\text{ V}$	V
$V_{IL}$	Input Low Voltage		-0.5	0.8	V
$V_{CC}$	Device Power		3.0	3.6	V
$I_{LIT}$	High Voltage Input Load Current	$V_{CC} = V_{CCmax}$ , A9, OE# = 12.5 V		35	$\mu\text{A}$

## AC CHARACTERISTICS

## Sector Protect/Unprotect Timing Operations

Parameter Symbol	Description		All Speed Options	Unit
Standard				
$t_{ACC}$	Address to Output Delay (Note 1)	Max	120	ns
$t_{OE}$	Output Enable to Output Delay (Note 1)	Max	28	ns
$t_{VIDR}$	Voltage Transition Time (Note 2)	Min	500	ns
$t_{WPP1}$	Write Pulse Width (Note 3)	Min	100	$\mu\text{s}$
$t_{WPP2}$	Write Pulse Width (Note 4)	Min	10	ms
$t_{OESP}$	OE# Setup Time to WE# Active (Note 2)	Min	4	$\mu\text{s}$
$t_{CSP}$	CE# Setup Time to WE# Active (Note 2)	Min	4	$\mu\text{s}$
$t_{ST}$	Voltage Setup Time	Min	4	$\mu\text{s}$

**Notes:**

1. If higher performance specifications for  $t_{ACC}$  and  $t_{OE}$  are required, refer to the Read Operations table in the AC Specifications section of the Am29BL16xC data sheet.
2. Not 100% tested.
3. These timings are for Sector Protect operation.
4. These timings are for Sector Unprotect operation.

## SECTOR PROTECTION/UNPROTECTION VERIFY (HIGH VOLTAGE MODE)

Type	WE#	CE#	OE#	A9	A19–A12	A6	A1	A0	DQ7–DQ0 (Hex)
Verify Sector Protection	$V_{IH}$	$V_{IL}$	$V_{IL}$	$V_{ID}$	Sector Addresses*	$V_{IL}$	$V_{IH}$	$V_{IL}$	01h
Verify Sector Unprotection						$V_{IH}$			00h

\* Refer to the Am29BL162C datasheet for sector address tables.

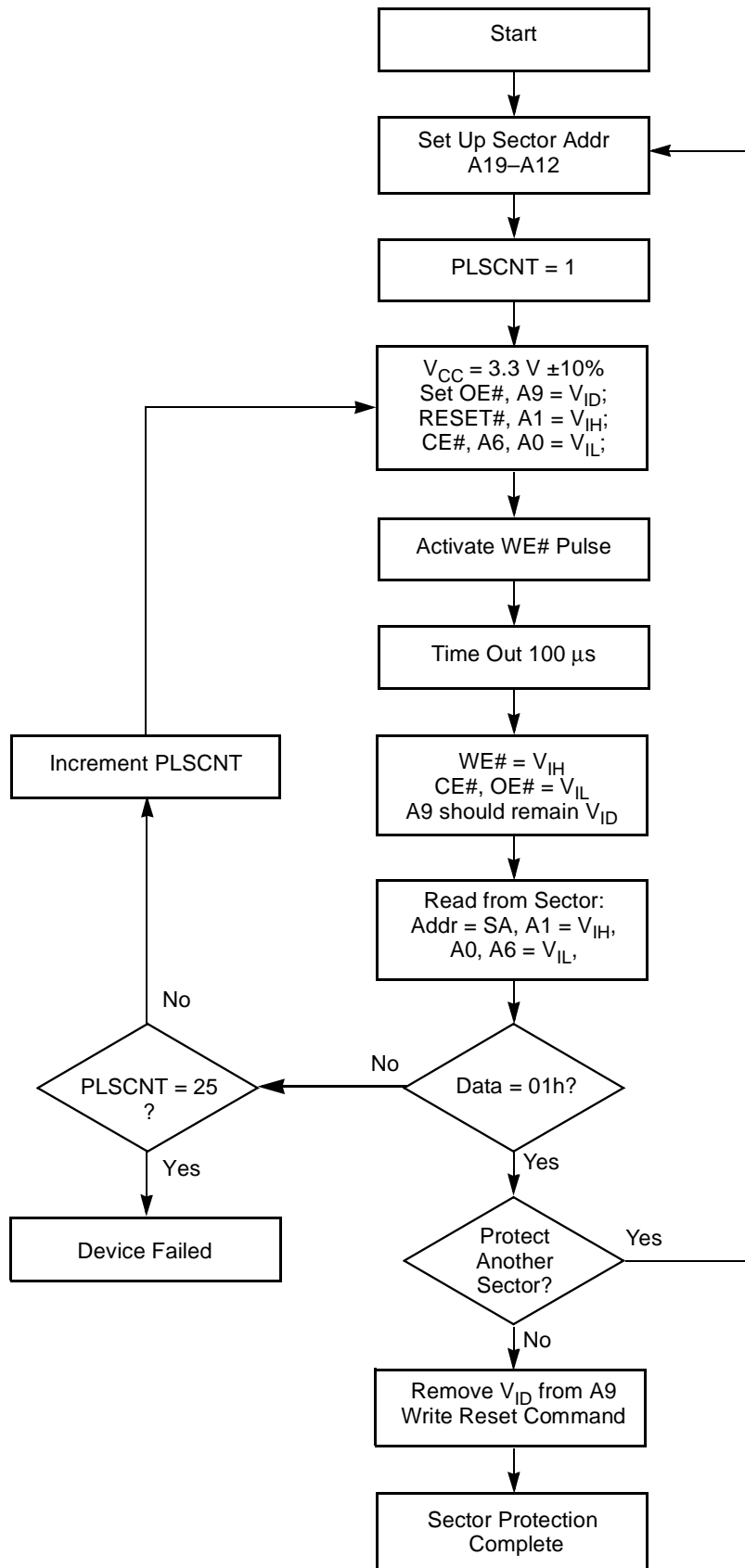
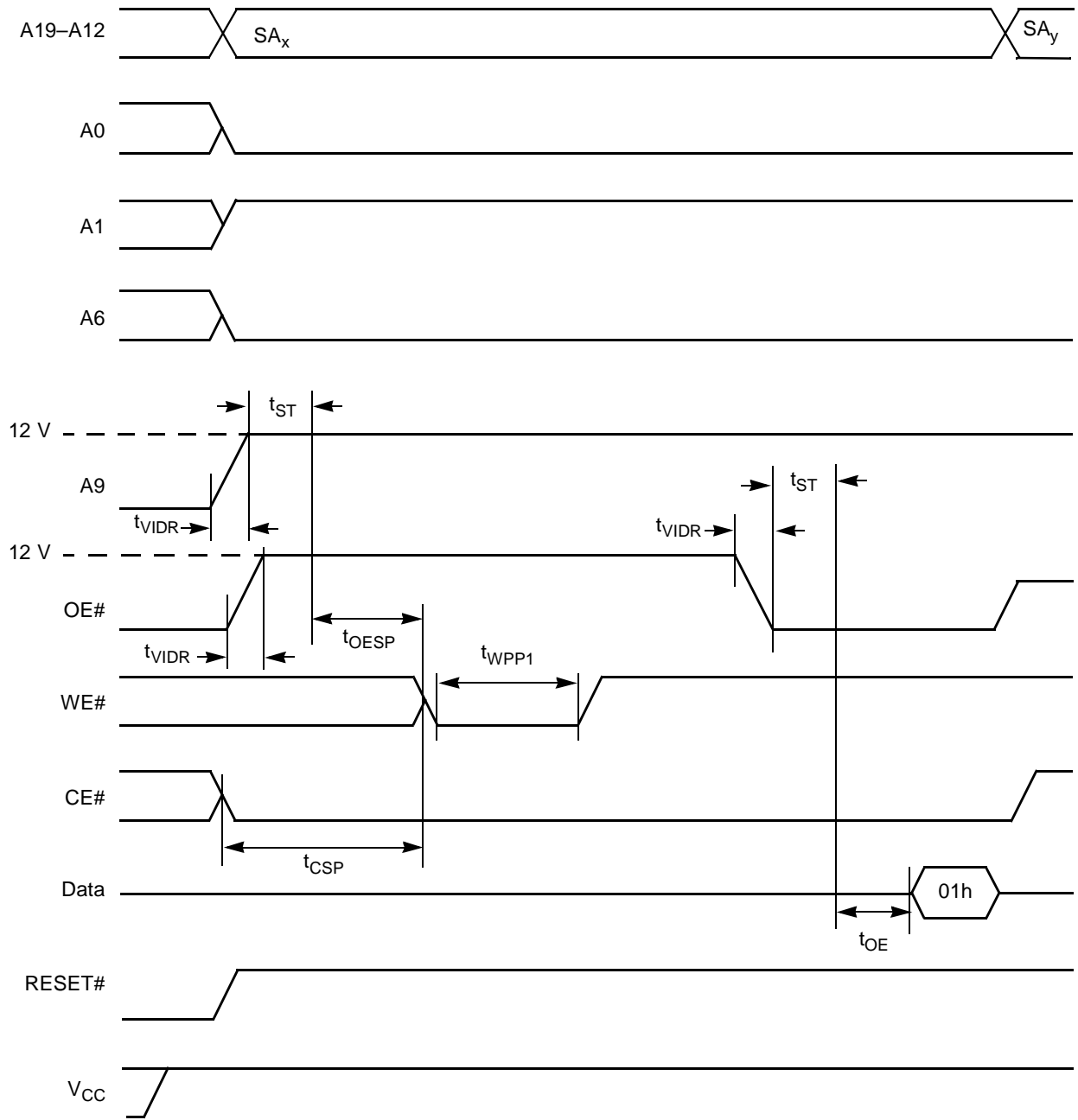

Figure 1. Sector Protection Algorithm

22240B-1



$SA_x$  = Sector Address for initial sector  
 $SA_y$  = Sector Address for next sector

22240B-2

Figure 2. AC Waveforms for Sector Protection

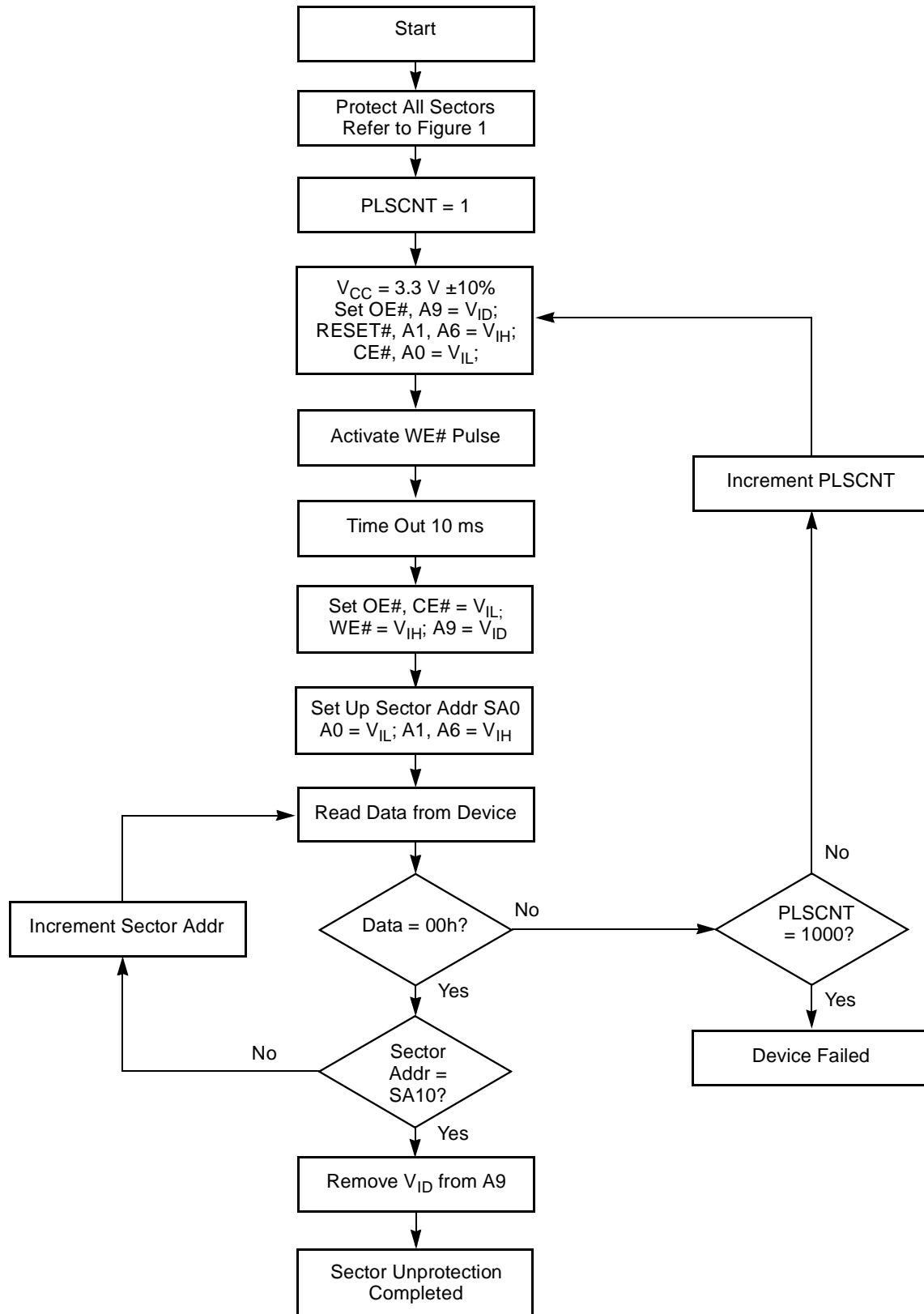

22240B-3

Figure 3. Sector Unprotect Algorithm

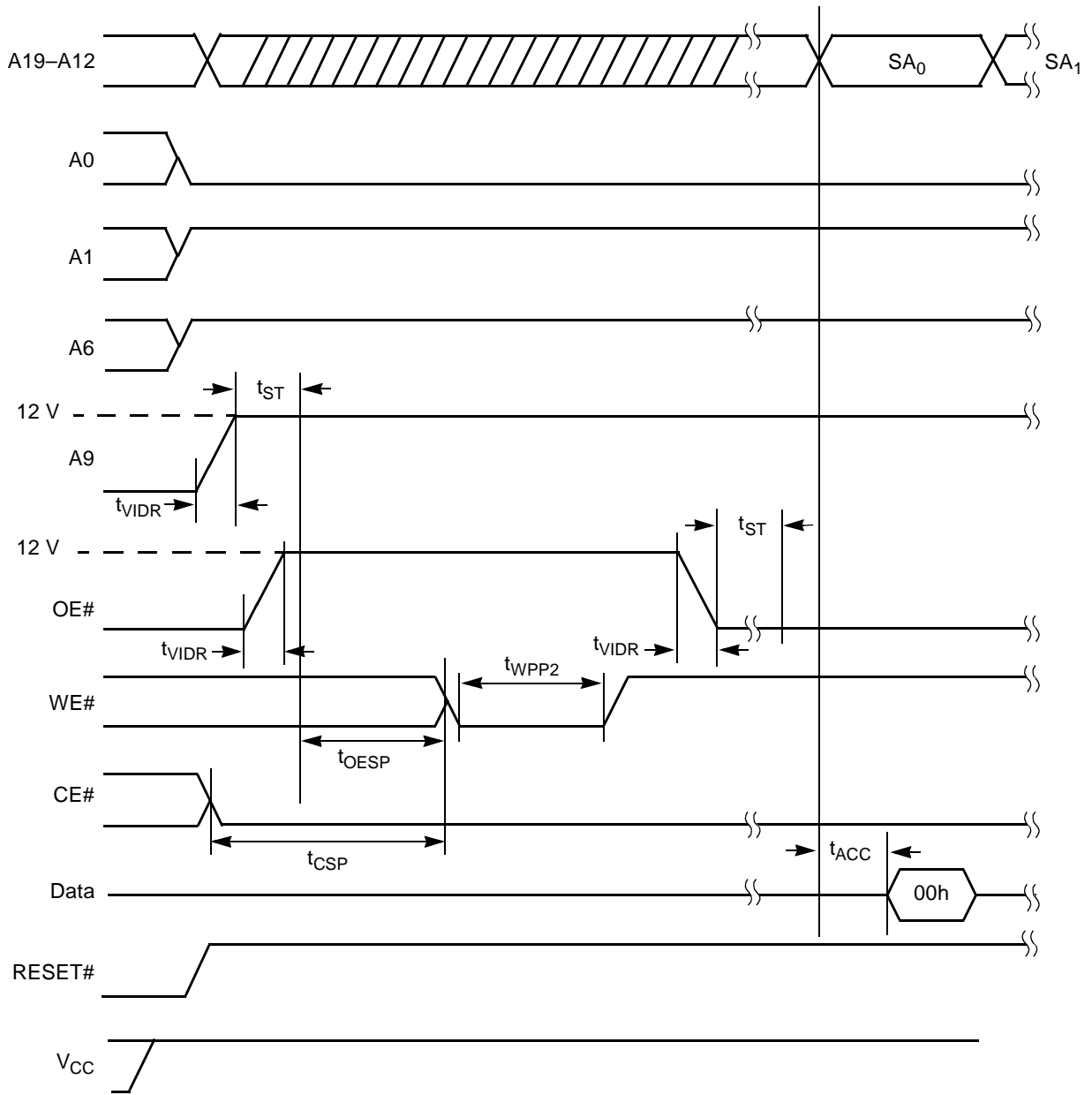

22240B-4

Figure 4. AC Waveforms for Sector Unprotect

Trademarks

Copyright © 1999 Advanced Micro Devices, Inc. All rights reserved.

AMD, the AMD logo, and combinations thereof are registered trademarks of Advanced Micro Devices, Inc.

Product names used in this publication are for identification purposes only and may be trademarks of their respective companies.